



OWNERS MANUAL

2008

RMTFITNESS

A division of

RehaMed International, LLC.

522 W. Mowry Drive • Homestead, FL 33030

Toll Free: 800-577-4424

<http://www.groupfmt.com>

TABLE OF CONTENTS

Introduction

Intended Use.....	Page 3
Safety Information.....	Page 3

VitaGlide

Component Diagram.....	Page 5
Parts List.....	Page 5
Assembly Instructions.....	Page 6
Specifications.....	Page 6
Operating Instructions.....	Page 7

VitaGlide Pro

Component Diagram.....	Page 9
Parts List.....	Page 9
Assembly Instructions.....	Page 10
Specifications.....	Page 11
Seat Assembly Instructions.....	Page 12
Operating Instructions.....	Page 13

Accessories

VitaGloves.....	Page 14
Tri-Post Adapter.....	Page 14

Maintenance.....	Page 14
-------------------------	----------------

Warranty Information.....	Page 15-16
----------------------------------	-------------------

INTRODUCTION

INTENDED USE

VitaGlide and VitaGlide Pro are exercise machines designed to provide a thorough upper-body workout.

This handbook contains important information on the assembly and operation of your VitaGlide. To get the best results, please take the time to read this manual completely.

SAFETY INFORMATION

As with any piece of equipment, please exercise caution and common sense while operating or handling the **VitaGlide** and **VitaGlide Pro**.

Please be aware of the following potential pinch points:

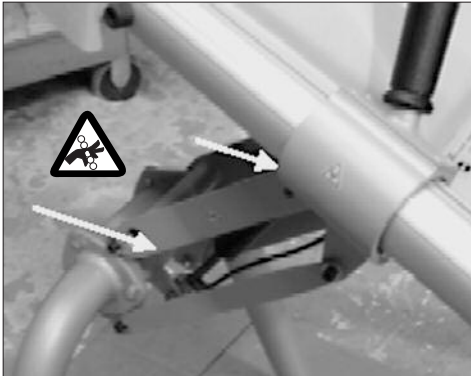

SEE YOUR PHYSICIAN

Before beginning any exercise program or changing your physical activity patterns, you should always consult with your doctor or physician, particularly if you have been inactive, are very overweight, or have or suspect any sort of medical condition that might be worsened by exercise.

VitaGlide is a registered trademark of RehaMed International, LLC.



The Standard VitaGlide is designed for use in the home.



VITAGLIDE COMPONENTS

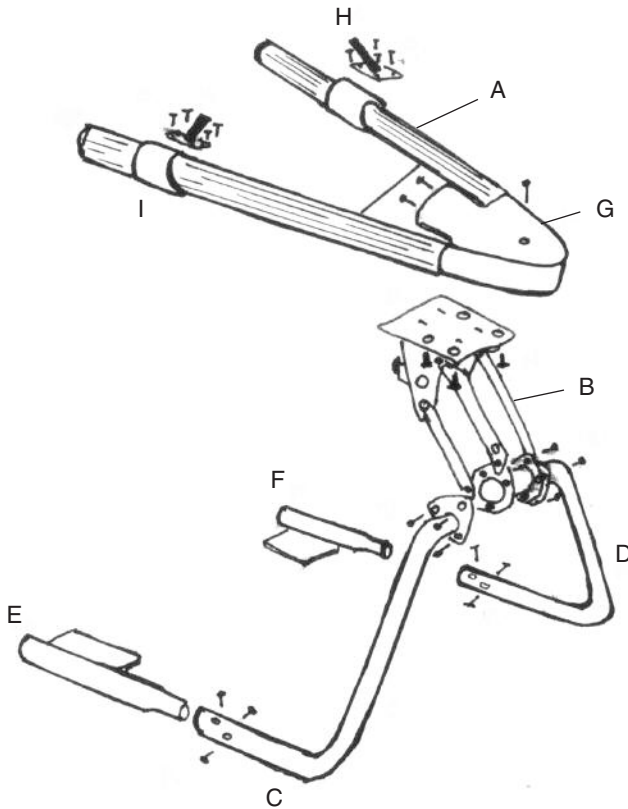

Part Number	Description	Letter Code
VGA100	V Section	A
VGH200	Strut Assembly	B
VGH320	Right Leg Assembly	C
VGH330	Left Leg Assembly	D
VGH322	Right Straight Leg Tube	E
VGH331	Left Straight Leg Tube	F
VGH700	Housing	G
VGA145	Handle Assembly	H
VGA140	Car Assembly	I

VITAGLIDE ASSEMBLY INSTRUCTIONS

1. Attach Left Leg Assembly (D) to Left Straight Leg Tube (F) using (3) #10 x 5/8 Self Drilling Philips Screws.
2. Attach Right Leg Assembly (C) to Right Straight Leg Tube (E) using (3) #10 x 5/8 Self Drilling Philips Screws.
3. Attach Left Leg Assembly (D) to Strut Assembly (B) using (3) 1/4 x 1/2 Screws.
4. Attach Right Leg Assembly (C) to Strut Assembly (B) using (3) 1/4 x 1/2 Screws.
5. Attach V-Section (A) to Strut Assembly (B) using (4) 5/16 x 3/4 18 Thread Bolts.
6. Attach Handles (H) to V-Section (A) using eight (8) 6/32" x 3/8" Screws.
Make sure that the handle is angled upward (facing the housing) while attaching.

*Please call RMT Fitness at 800-577-4424
if you have any problems or questions with assembly.*



VITAGLIDE OPERATING INSTRUCTIONS

1. Prior to operation, make certain that the VitaGlide is in the completely raised position by pushing the red lever located below the center console and manually lifting the V-Section with your hands or arms.
2. Approach the VitaGlide from the open portion of the V-Section
3. Position yourself at a distance where the midpoint your hips are directly below the end caps of the V-Section, ensuring that the wheels of your wheelchair are resting on the flat platforms of the VitaGlide's base.
4. Lock the wheels of your wheelchair (if applicable)
5. Lower the V-section until the end caps are in-line with your hips. To lower the unit, push the red lever while manually lowering the V-Section with your hands or arms.*
6. Position hands around the black handles located on each track of the V-Section, and push with one arm while pulling with the other. For best results, make certain to achieve a full range of motion while operating the unit. This is accomplished by ensuring that your pushing arm is fully extended at the end of the stroke.
7. For users with limited or no grip, operation of the VitaGlide's handles can be facilitated by using either Tri-Post Adaptors or VitaGloves (each sold separately.)
8. To effectively operate the VitaGlide, the pace and motion of your stroke should mimic that of jogging or cross-country skiing.
9. Users can regulate the resistance in the workout by adjusting the Intensity Lever located on the center console to anywhere from Level 1 Intensity (lightest) to Level 7 Intensity (maximum resistance.)
10. To ensure maximum cardiovascular benefit, workout durations should typically last 15-30 minutes, if possible**.
11. Following completion of workout, make certain that the VitaGlide is in the completely raised position by pushing the red lever below the center console while manually lifting the V-Section with your hands or arms.

* Some Power Wheelchairs may not permit the unit to completely lower to the appropriate position. Power Chair users should remove or fold away the armrests (if possible) of the wheelchair prior to using the VitaGlide. In the event that the armrests will not move, lower the V-section to the lowest possible point above the armrests, while ensuring that the unit does not make contact with the chair.

** Before beginning any exercise program or changing your physical activity patterns, you should always consult with your doctor or physician, particularly if you have been inactive, are very overweight, or have or suspect any sort of medical condition that might be worsened by exercise.

SPECIFICATIONS

Height:	
Raised:	40 inches
Lowered:	32 inches
Length:	45.5 inches
Width:	35 inches
Weight:	65 lbs.

Materials

Housing:	ABS Plastic
Rails:	Extruded Aluminum
Cars:	Extruded Aluminum
Trucks:	Extruded Aluminum
V-Section:	Cast Aluminum
Handles:	Aluminum Tubing with Plastic Grips
Strut Assembly:	Steel
Legs:	Steel Tubing

Resistance Assembly

Friction Brake	
Brake Wheel:	Stainless Steel
Brake Arms:	Aluminum
Brake Pads:	Composite Brake Lining Material (non-asbestos)
Resistance Lever:	Steel

VITA GLIDE PRO

The VitaGlide Pro is designed for commercial use, including health clubs, wellness centers, rehabilitation and physical therapy clinics, and gyms.



VITAGLIDE PRO COMPONENTS

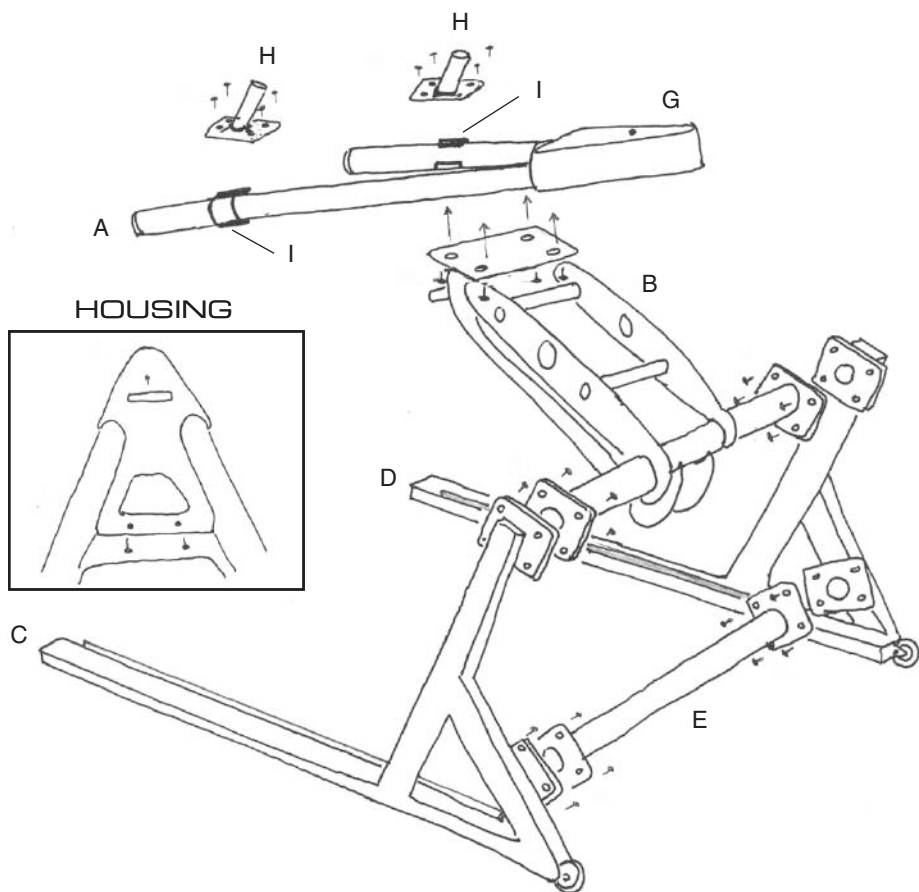

Part Number	Description	Letter Code
VGA100	V Sector	A
VGP200	Strut Assembly	B
VGP320	Right Base Leg Assembly	C
VGP330	Left Base Leg Assembly	D
VGP310	Lower Support Tube	E
VGP600	Seat Assembly	F
VGP700	Housing	G
VGA145	Handle Assembly	H

VITAGLIDE PRO ASSEMBLY INSTRUCTIONS

1. Position Base Assembly in proper orientation.
2. Attach V-Section to Mounting Plate using (4) 5/16" Bolts
3. Attach Handles to Cars using (8) 6/32 x 3/8 screws.
4. Place (3) AAA batteries in receptacle located in housing. Test timer to insure it is operating.
5. Position Housing onto V-Section and align the (3) lock screws with the corresponding holes on the V-Section.
6. Secure the Housing onto the V-Section by tightening the lock screws with 1/4 turn each.

*Please call RMT Fitness at 800-577-4424
if you have any problems or questions with assembly.*

SEAT ASSEMBLY INSTRUCTIONS

1. Attach Seat (A) to the Seat Stem (B) using four (4) 5/16" x 3/4" Bolts.
2. Attach Front Seat Gusset (D) to Seat Stem (B) using two (2) 5/16" x 3/4" Bolts. **Do not fully tighten Bolts!**
3. Attach Rear Seat Gusset (E) to Seat Stem (B) using one (1) 5/16" x 3/4" Bolt. **Do not fully tighten Bolts!**
4. Attach Front Seat Gusset (D) to Roller Assembly (C) using three (3) 5/16" x 3/4" Bolts. **Do not fully tighten Bolts!**
5. Attach Rear Seat Gusset (E) to Roller Assembly (C) using two (2) 5/16" x 3/4" Bolts. **Do not fully tighten Bolts!**
6. Fully tighten all bolts.

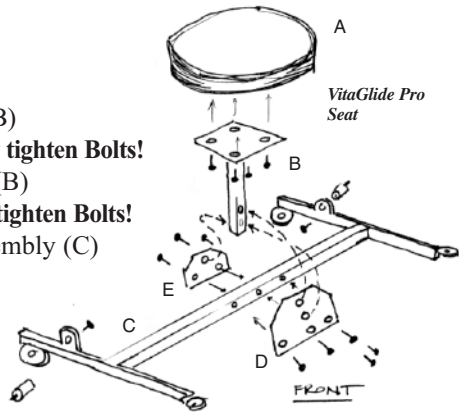

SEAT ASSEMBLY PARTS LIST

VGP610	Seat Cushion	A
VGP614	Seat Plate	B
VGP630	Roller Assembly	C
VGP620	Front Seat Gusset	D
VGP625	Rear Seat Gusset	E

VITAGLIDE PRO OPERATING INSTRUCTIONS

1. Prior to operation, make certain that the VitaGlide Pro is in the completely raised position by pushing the red lever located below the center console and manually lifting the V-Section with your hands or arms..
2. Approach the VitaGlide Pro from the open portion of the V-Section
3. Position yourself at a distance where the midpoint your hips are directly below the end caps of the V-Section
4. Lock the wheels of your wheelchair (if applicable)
5. Lower the V-section until the end caps are in-line with your hips. To lower the unit, push the red lever located below the center console and manually lower the V-Section with your hands or arms.
6. Position hands around the black handles located on each track of the V-Section, and push with one arm while pulling with the other. For best results, make certain to achieve a full range of motion while operating the unit. This is accomplished by ensuring that your pushing arm is fully extended at the end of the stroke.
7. For users with limited or no grip, operation of the VitaGlide Pro's handles can be facilitated by using either Tri-Post Adaptors or VitaGloves (each sold separately.)
8. To effectively operate the VitaGlide Pro, the pace and motion of your stroke should mimic that of jogging or cross-country skiing.
9. Users can regulate the resistance in the workout by adjusting the Intensity Lever located on the center console to anywhere from Level 1 Intensity (lightest) to Level 7 Intensity (maximum resistance.)
10. The center console is equipped with a digital timer/pulse monitor. To activate or pause timer, press the button located just above the "Start/Stop" indicator. To reset the time, simply press the button located above the "Reset" indicator. The pulse monitor is compatible with any Polar pulse monitoring system. The digital display will alternate every ten seconds between duration of workout and pulse rate.
11. To ensure maximum cardiovascular benefit, workout durations should typically last 15-30 minutes, if possible**.
12. Following completion of workout, make certain that the VitaGlide Pro is in the completely raised position by pushing the red lever located below the center console and manually lifting the V-Section with your hands or arms.

* Some Power Wheelchairs may not permit the unit to completely lower to the appropriate position. Power Chair users should remove or fold away the armrests (if possible) of the wheelchair prior to using the VitaGlide Pro. In the event that the armrests will not move, lower the V-section to the lowest possible point above the armrests, while ensuring that the unit does not make contact with the chair.

** Before beginning any exercise program or changing your physical activity patterns, you should always consult with your doctor or physician, particularly if you have been inactive, are very overweight, or have or suspect any sort of medical condition that might be worsened by exercise.

SPECIFICATIONS

Height:	Raised:	45 inches
	Lowered:	33 inches
Length:		62 inches
Width:		39 inches
Weight:		285 lbs.

Materials

Housing:	ABS Plastic
Rails:	Extruded Aluminum
Cars:	Extruded Aluminum
Trucks:	Extruded Aluminum
V-Section:	Cast Aluminum
Handles:	Aluminum Tubing with Plastic Grips
Strut Assembly:	Steel
Base Assembly:	Steel

Resistance Assembly

Friction Brake	
Brake Wheel:	Stainless Steel
Brake Arms:	Aluminum
Brake Pads:	Composite Brake Lining Material (non-asbestos)
Resistance Lever:	Steel
Timer/Pulse Monitor	Powered by (3) AAA Batteries
Timer	Range: 0-60 minutes
Pulse Monitor	Compatible with Polar Equipment
Receiving	Signal: 5 khz

MAINTENANCE

General Maintenance

Keep the unit clean.

Check all connections at least once a month to insure tightness.

Clean pulleys at least once a month using compressed air.

Cars

The cars may become loose over a period of time. Loose cars can damage the rails. If the cars become loose, tighten the set screw, located in the center hole on the bottom of the car. Be careful not to overtighten the set screw.

ACCESSORIES

VitaGloves

Fabricated from VitaTex, a unique new fabric that does not retain moisture, VitaGloves are designed for users with limited gripping ability. They feature a unique cupped design to enclose the entire hand, especially the thumbs. The material contains numerous pores to permit air circulation.



VitaGloves are a perfect choice to assist with gripping any item that has a handle.

VitaGlove Features: 100% machine washable
 Available in two sizes
 Large: Fits wrists from 7.25"-10"
 Small: Fits wrists from 5.5"-7.25"

Fabricated with a vinyl binding, polypropylene webbing, and Velcro fastenings.

Tri-Post Adaptors

Adapts to any VitaGlide handle. Locks the wrist in place to enable users with very limited grip to use the VitaGlide independently without gloves.

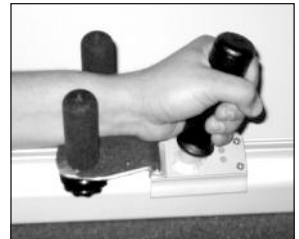

Installation and Use Instructions

When installing the Tri-Post Adaptors, make sure that the two adaptors are oriented properly. The Adaptor for the left side of the unit is marked with two dots. The Adaptor for the right side of the unit is marked with one dot.

Remove the two back screws from the handle. Position the Adaptor on the appropriate side and attach to the handle & car using the longer screws provided with the Tri-Post Adaptor Kit.

To use the Tri-Post Adaptors, position the user's hand around the handle and snug the two support posts against the wrist. Be sure the support posts do not rub against the wrist during use.

WARRANTY INFORMATION

All VitaGlide products feature a two-year warranty. Within the warranty period, we will repair or replace any part found to be defective upon our examination, but will not pay shipping costs or other expenses. This Warranty excludes the powder coated paint finish, which may become scratched with normal use. To obtain warranty service, call or write to us at the address provided. This warranty is an exclusive remedy and we are not responsible for any consequential or incidental damages or injury to person or property. This warranty shall not apply to any product which has been subject to misuse, negligence, or accident, or has been damaged in shipment, or misapplied, or which have been modified or repaired by an unauthorized person. This warranty only applies to products owned by persons purchasing directly from the manufacturer or from our approved dealers or distributors.

Warranty Procedures

To initiate a warranty claim, contact our customer service department. Once the nature of the problem has been determined the following procedure will be followed:

Within the first 90 days following delivery of the Product

A Return Merchandise Authorization (RMA) will be issued for the return of the defective component. This RMA number should be clearly displayed on the outside of the package containing the returned part.

RMT will pay all freight charges for any component that fails within the first 90 days.

The defective component will be inspected by our technical staff to determine if the product can be repaired. If the component cannot be repaired it will be replaced with a new component.

After the 90 days

A Return Merchandise Authorization (RMA) will be issued for the return of the defective component. This RMA number should be clearly displayed on the outside of the package containing the returned part.

The customer is responsible for all freight costs after 90 days.

The defective component will be inspected by our technical staff to determine if the product can be repaired. If the component cannot be repaired it will be replaced with a remanufactured component.

What if I can't wait for the defective component to be inspected?

If the customer desires that a replacement component be sent out immediately, the following procedures will be followed:

Once the problem component has been identified, a remanufactured component will be sent to the customer immediately.

The customer will be invoiced for the cost of a remanufactured component, generally 75% of the full price.

A Return Merchandise Authorization (RMA) will be issued for the return of the defective component. This RMA number should be clearly displayed on the outside of the package containing the returned part. The customer can use the same box that was used to ship the remanufactured component.

The customer will promptly return the defective component.

After inspection by our technical staff, if the defective component is covered under the terms of the warranty, a credit will be issued to cancel out the invoice issued for the component.

If the component is not covered under warranty, the invoice is payable by the customer.

RMT will pay all freight charges for components less than 90 days old. After 90 days, the customer pays all freight charges.

All returns will be processed promptly in our factory.

For further information, please contact our Customer Service Department at 305-247-8300.